

INSTRUÇÕES DE MONTAGEM
MÓVEL TV 2 PORTAS E 2 GAVETAS LISO

CANNES

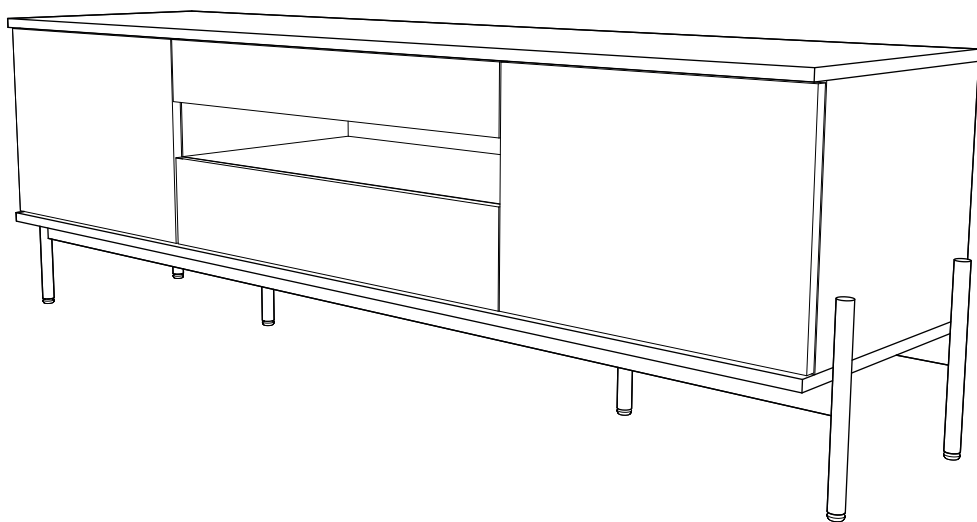

ANTARTE

design for life

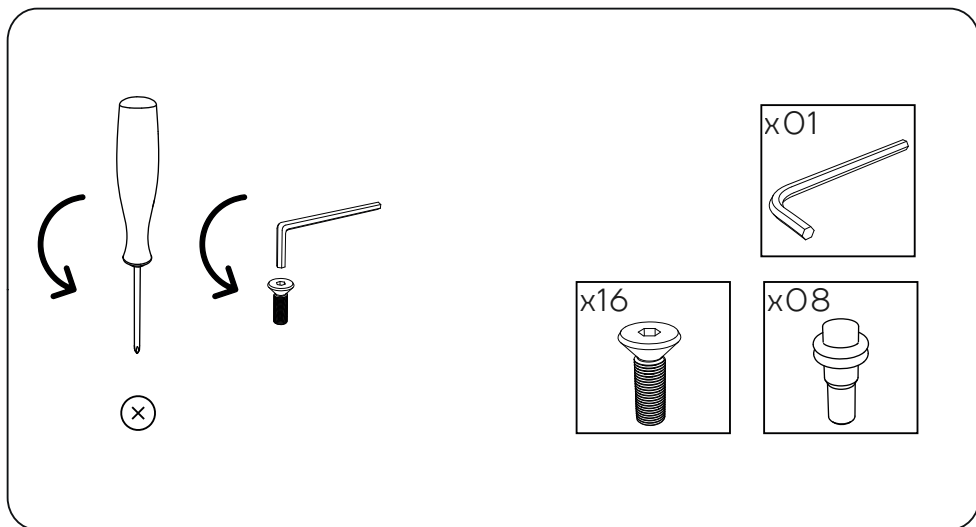

Obrigado pela sua preferência!

O design, a elegância e o conforto
estão agora mais perto de si!



01

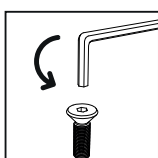
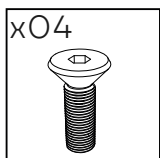
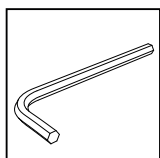
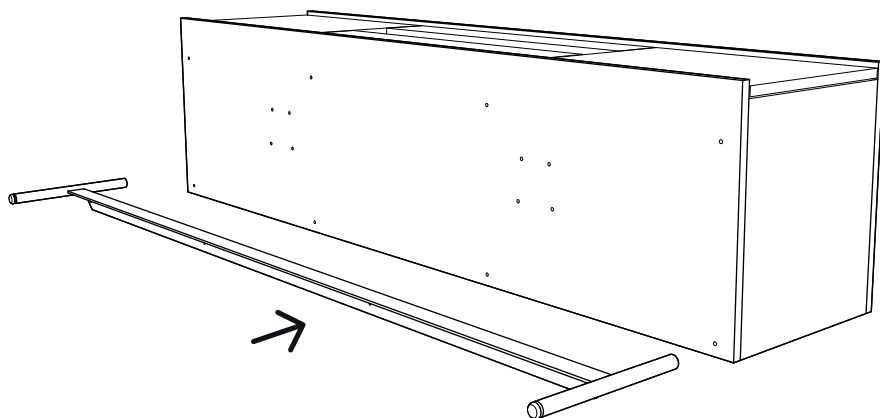

02

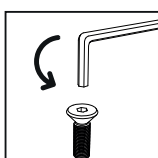
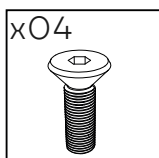
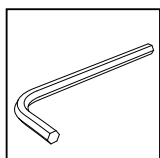
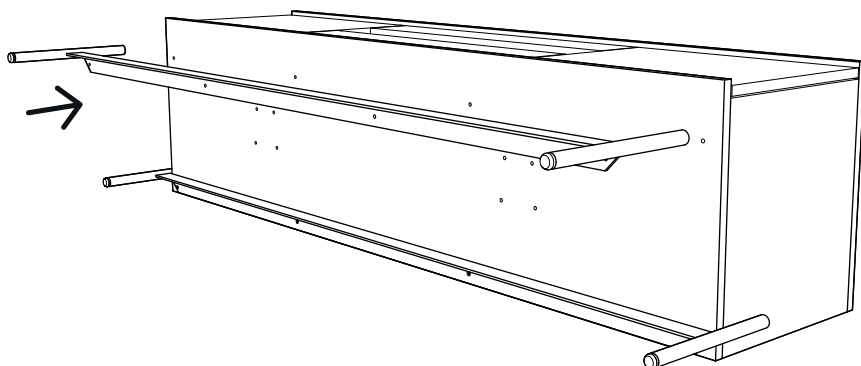

03

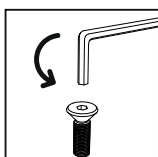
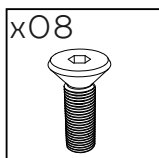
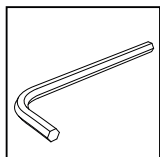
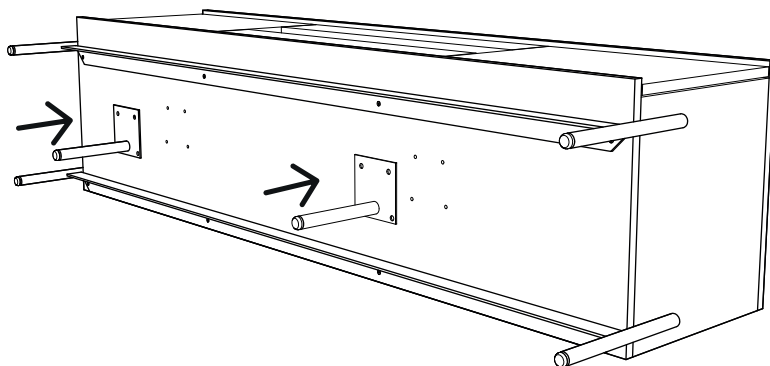

04

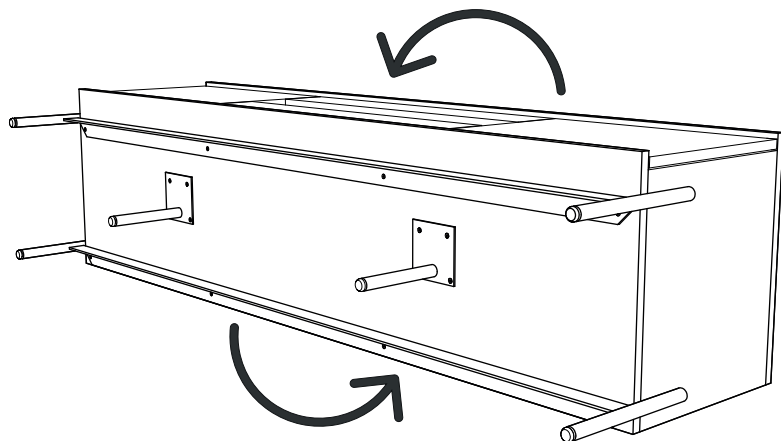

05

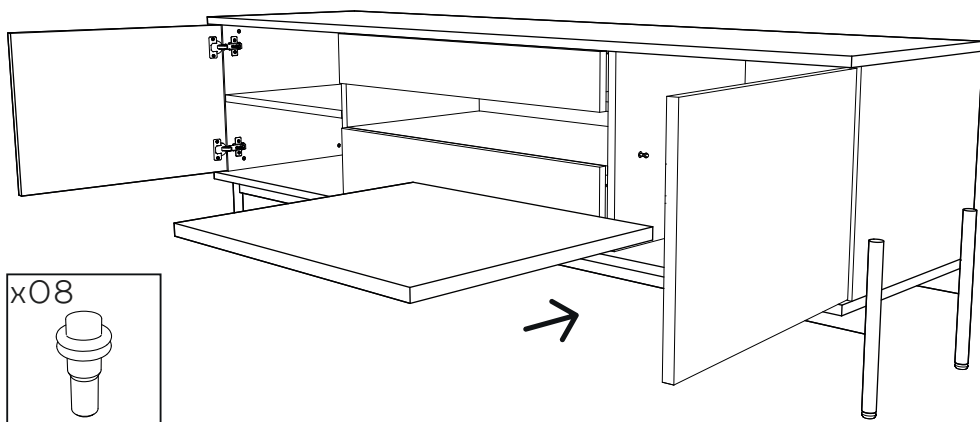

AFINAÇÃO DOS PÉS

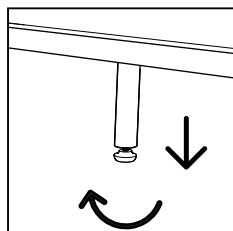
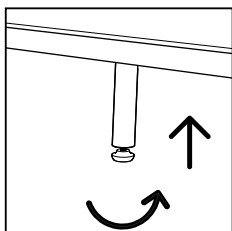

AFINAÇÃO DA PORTA

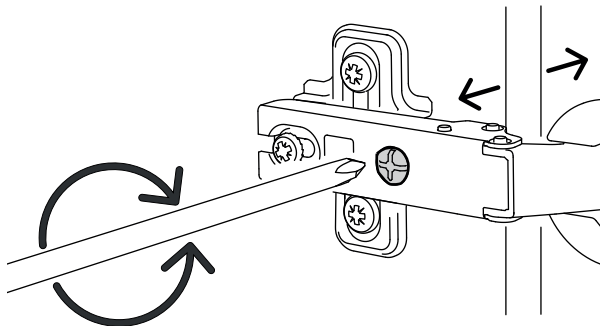
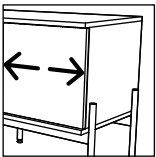
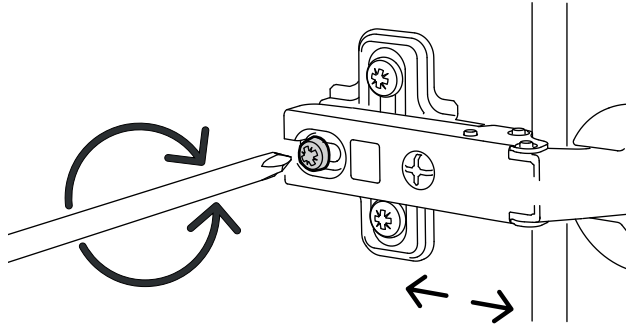
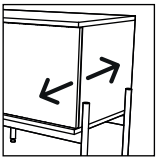
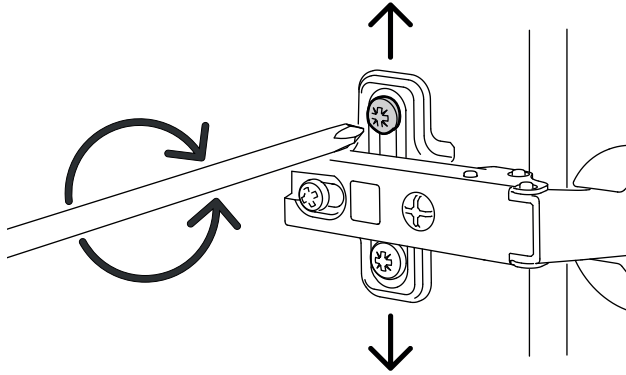
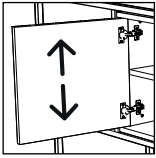

AFINAÇÃO DA GAVETA

CORREDIÇA LADO ESQUERDO

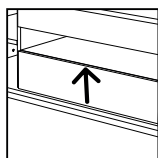
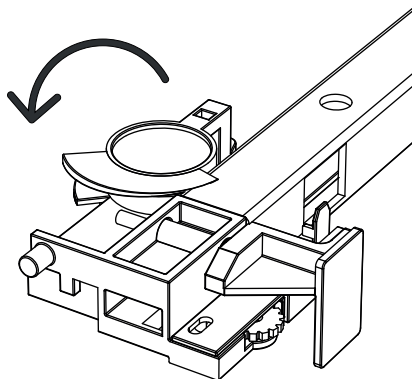
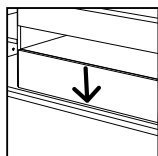
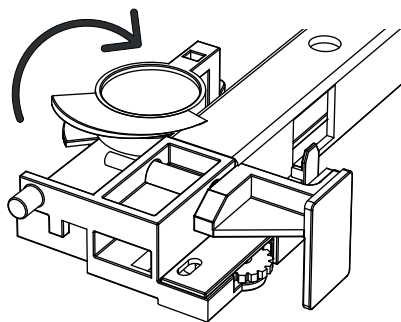

CORREDIÇA LADO DIREITO

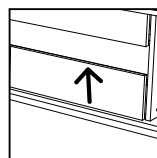
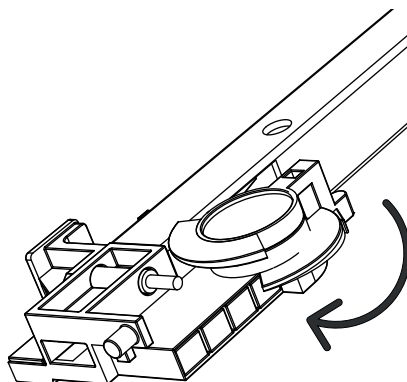
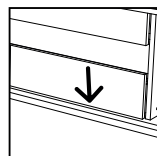
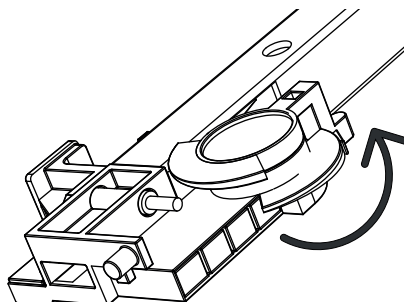



ANTARTE

design for life

SEDE:

AV. DA ZONA INDUSTRIAL, 222
4585-303 REBORDOSA

PAREDES, PORTUGAL

+351 224 119 350

(chamada para a rede fixa nacional)

ANTARTE@ANTARTE.PT

WWW.ANTARTE.PT